

Thomson Electrak[®] GX Electric Linear Actuator

Installation Manual

Edition 2026-01



Version history

Edition	Reason for revision
2022-02	First edition
2026-01	Updated front and back cover logotypes and layout

Warranty

The Thomson Electrak® GX is warranted to be free from defects in materials and workmanship for a period of twelve (12) months from date of manufacture. The application of this product is the responsibility of the buyer and Thomson makes no representation or warranty as to the suitability of the product for any particular use or purpose. For a copy of the entire warranty for this product that is contained in our standard terms and conditions of sale, please go to http://www.thomsonlinear.com/website/com/eng/support/terms_and_conditions.php.

Disclaimer

Technical changes to improve the performance of the equipment may be made without prior notice!

All rights reserved. No part of this work may be reproduced in any form (by printing, photocopying, microfilm or any other method) or processed, copied or distributed by electronic means without the written permission of Thomson.

Contents

- 1. General 4**
 - 1.1 About this manual 4
 - 1.2 Target group 4
 - 1.3 Symbols used 4
 - 1.4 Transport and storage 4
 - 1.5 Packaging 4
 - 1.6 Disposal 4
 - 1.7 Support 4

- 2. Safety 5**
 - 2.1 Safety notes 5

- 3. Standards 5**
 - 3.1 EC Declaration of conformity 5

- 4. Installation 6**
 - 4.1 Product identification and product label 6
 - 4.2 Terminology 6
 - 4.3 Operation environment 7
 - 4.4 Mechanical installation 7
 - 4.5 Electrical installation 10

- 5. Technical specifications 13**
 - 5.1 General specifications 13
 - 5.2 Weight for dc input voltage units 13
 - 5.3 Weight for ac input voltage units 13
 - 5.4 Weight for dc input voltage units 13
 - 5.5 Technical data for dc input voltage units 14
 - 5.6 Technical data for ac input voltage units 15

- 6. Ordering keys 16**
 - 6.1 Ordering key for dc voltage models 16
 - 6.2 Ordering key for ac voltage models 17

1. General

1.1 About this manual

This manual contains mechanical and electrical installation instructions for the Thomson Electrak® GX electric linear actuator. It also contains, among other things:

- technical data
- installation data
- type designation key.

It is important to carefully read this manual before installing the actuator and to have the correct qualifications needed to perform the installation.

1.2 Target group

This manual addresses qualified mechanical and electrical personnel.

1.3 Symbols used



This symbol is shown to highlight a general warning, general instruction or as a warning for a mechanical hazard.

1.4 Transport and storage

The actuator may only be transported and stored in the original packaging supplied by Thomson. The temperature during transportation and storage must be between -25 to +65° C (-15 to +150° F). Avoid shocks to the package. If the package is damaged, check the actuator for visible damage and notify the carrier, and if appropriate also Thomson.

1.5 Packaging

The packaging consists of a cardboard box. The box contains the actuator and this manual. For large quantity orders bulk packaging may be used in which case the packaging and the content will vary depending on the order agreement.

1.6 Disposal

Where required by law, used packaging and actuators are taken back by Thomson for professional disposal if the transportation cost is paid by the sender. Please contact Thomson for shipping information.

1.7 Support

If technical support or information is needed for this product, please contact the nearest Thomson Service Center. See the back of this manual. You can also visit www.thomsonlinear.com for information on this product and how to contact us.

2. Safety

2.1 Safety notes



- Only properly qualified personnel are permitted to perform mechanical and electrical installation of this product. Properly qualified personnel are familiar with mechanical or electrical installation work and have the appropriate qualifications for their job.
- Read this manual and any other available documentation before working on the equipment that the actuator is or shall be a part of.
- Conform strictly to the information contained in this manual and on the actuator product label on the actuator. Never exceed the performance limits stated herein.
- Never work on the actuator or its installation with the power on.
- Never unplug any cables or connectors during operation or with power on.
- Immediately stop using the actuator if it seems faulty or damaged in any way and notify an appropriate person so that corrective actions can be taken.
- Never open the actuator as that will compromise the sealing and the function of the actuator. There are no serviceable components inside.
- Grease may be present on the extension tube. Contact is non-hazardous. Film should not be removed.

3. Standards

3.1 EC Declaration of incorporation of partly completed machinery

We, Thomson Linear declare that this products corresponds with the directive 2006/42/EC, RoHSIII directive 2015/863, WEEE directive 2012/19/EU, low voltage directive 2014/35/UE and also with the directive of electromagnetic compatibility 2014/30/UE and that the standard EN ISO 12100:2010, Safety of machinery, have been applied.

<p>Thomson Electrak® GX Product</p>	<p>Linear Actuator Description</p>
--	---

Can be used when the machine or the system, which it shall be, a part of is in accordance with the demands in the EEC Machinery Directive and/or other relevant regulations.

Kristianstad 2021-11-08
.....
Date

Håkan Persson
.....
Name

Business Unit Manager
.....
Title

.....
Signature

4. Installation

4.1 Product identification and product label

4.1.1 Units without product label

These units, which are not CE marked, have the manufacturing date and the designation of the actuator engraved on the housing. The performance data for your actuator must be looked up in this manual. Please study the performance data for your actuator before starting any installation or service. If you need any assistance from Thomson, please provide the manufacturing date and the designation of the actuator(s) in question.

4.1.2 Units with product label

These units have a product label on the the cover tube. The label details which model of actuator you have, its basic performance data, if it is CE marked or not and where it is manufactured. Please study the product label to determine actuator type and its performance data before starting any installation or service. If you need any assistance from Thomson, please provide the manufacturing date and the designation of the actuator(s) in question.

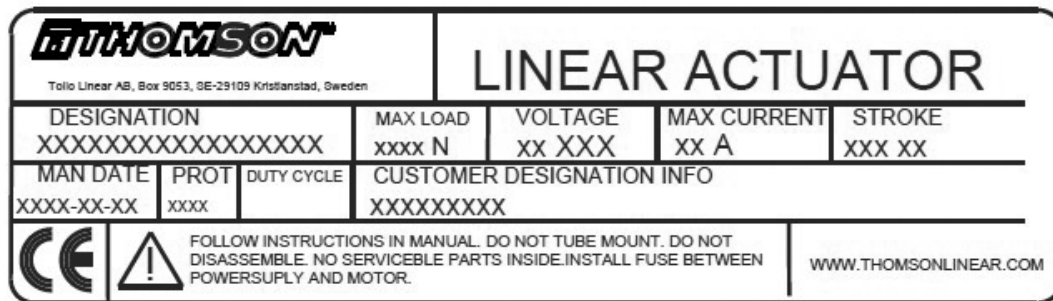

4.2 Terminology

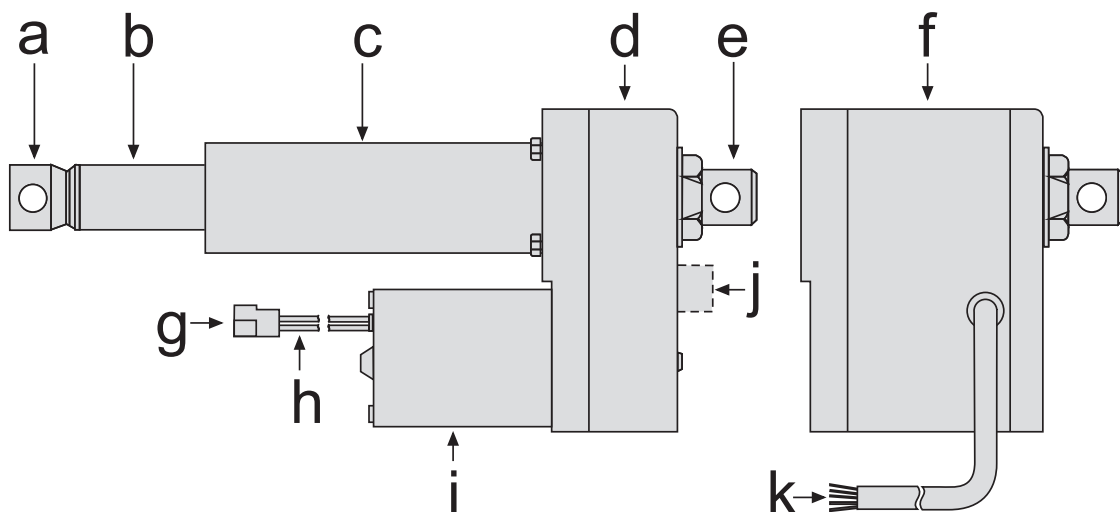

a. front adapter

d. housing (standard)

g. connector

j. hand wind input

b. extension tube

e. rear adapter

h. electrical wires

k. cable if option potentiometer

c. cover tube

f. housing if option potentiometer

i. motor

4.3 Operation environment



Min. -25° C (-15° F) Max. +65° C (+150° F) Vdc units: IP66 or IP66/IP69K
 Vac units: IP45

1. Operation temperature range is -25 to +65° Celsius (-15 to +150° Fahrenheit).
2. Protection degree against the ingress of water and particles is for dc voltage units IP66 or IP66 and IP69K depending on option (see the product label or/and the actuator designation), and for ac voltage units IP45.
3. Relative humidity range is 10 - 90% non-condensing.

4.4 Mechanical installation

4.4.1 General installation safety notes



- Never work on the actuator with the power switched on!
- Do not hold the extension tube while the unit is energized.
- Failure modes of the actuator should be considered to ensure it does not create harm.

4.4.2 Basic installation considerations

1. Only mount the actuator using the holes in the front and rear adapters. Identify the model designation of the actuator (section 4.1) and then look at the ordering key (section 6) to find out your adapter type configuration. See the below drawings to find out the exact dimensions.
2. Make sure that the actuator mounting position allows access to the connector or cable(s) to allow the actuator to be connected or disconnected when required.
4. If the actuator is equipped with the hand wind option, the hand wind input must have enough free space around it to allow it to be operated (section 4.4.6).

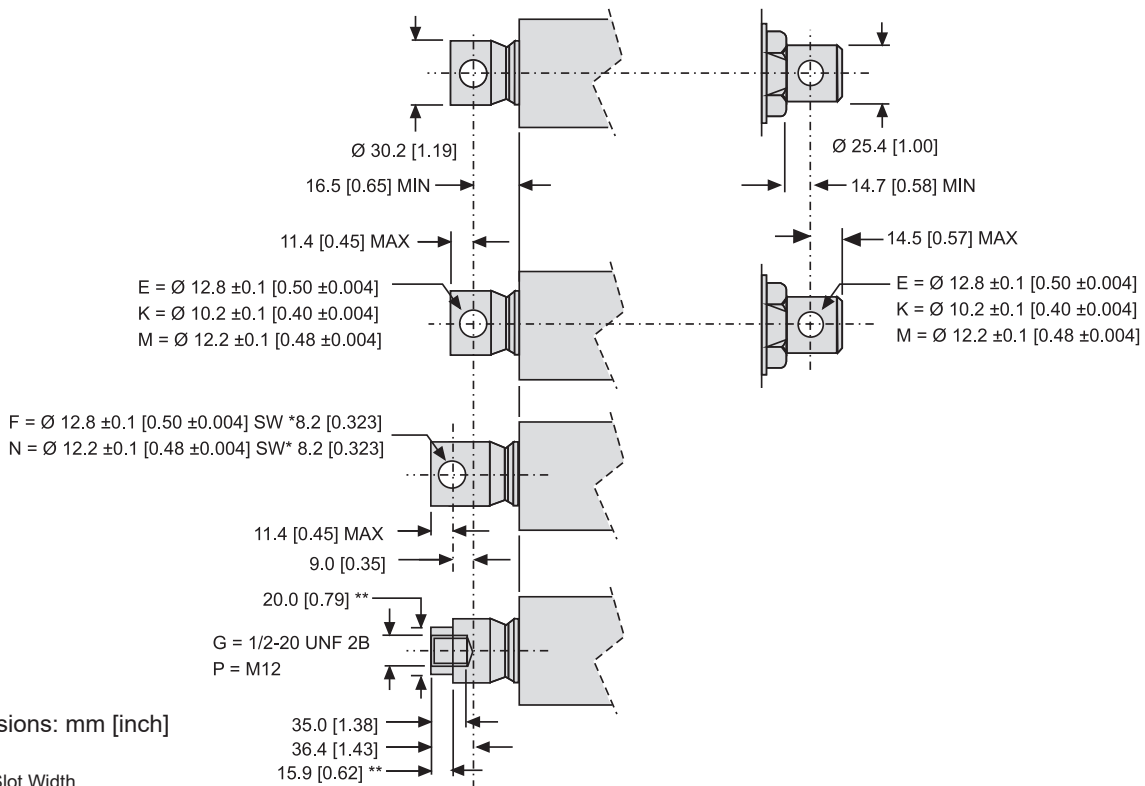

4.4.3 Mounting orientation and forces

1. The actuator can be mounted in any orientation and handle both pushing and pulling loads.
2. Always install actuator so that the force of the load acts in the center of the extension tube and the rear adapter.
3. Only mount the actuator to the rear and front adapter mounting holes.
4. Only use solid mounting pins and support them at both ends.
5. The mounting pins must be parallel to each other both radially and axially.

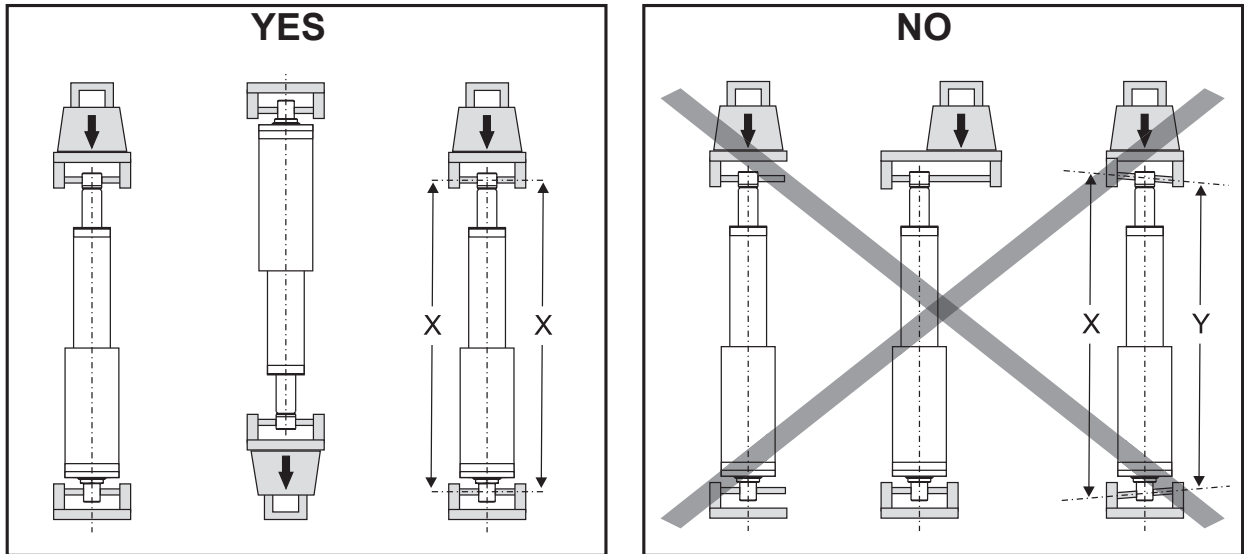

4.4.4 Restraining torque

The rear and the front adapter must be fixed by a method that can restrain the torque produced by the extension tube, which for Electrak GX is 11.3 Nm (100 lbf-in). If not restrained in both ends, the extension tube (or the actuator) will rotate instead of moving.

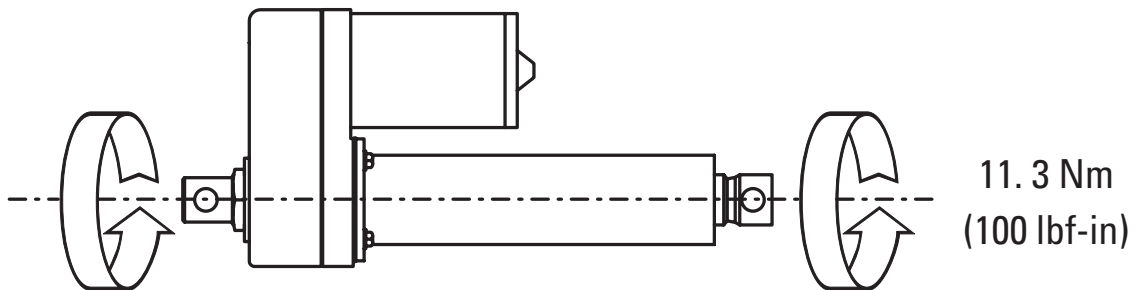

4.4.5 Slip clutch

The actuator is protected by a load limiting mechanical clutch which prevents the motor from stalling at either end of the actuator stroke. It will also slip at any point along the stroke when the factory-set load limit (1.2 - 1.5 × the dynamic load rating) is exceeded. Stop the actuator immediately if the clutch is engaged and in case of mid-stroke engagement also investigate the cause.

4.4.6 Hand wind mounting and operation considerations (optional feature)

1. Make sure when mounting the actuator that there is space enough between the rear adapter and any object behind it to allow the hand wind to be operated!
2. To be able to operate the hand wind, remove the cover plug placed over the hand wind input.
3. Next, move the extension tube by turning the hand wind input hexagon socket (a) using a 6 mm hexagon key (b).
4. The maximum torque required to move the extension tube at the fully rated actuator load using the hand wind is typically 1.5 - 2.5 Nm (13 - 22 in-lb) depending of the model.

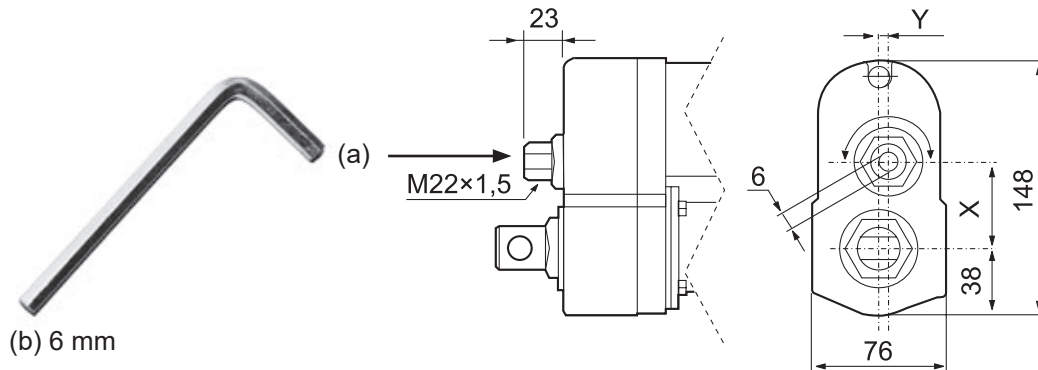

Model	X	Y
D(A)xxxO5A(B)5-	49.6	0.0
D(A)xxx10A(B)5-	43.3	5.2
D(A)xxx20(21, 2K)A(B)5-	38.9	0.0



- Always make sure to switch off the power to the actuator before using the hand wind.
- Do not apply higher torque than 5 Nm (44 in-lb) to the hand wind input.
- Stop running the extension tube immediately if the slip clutch (see section 4.4.5) is engaged.
- Never use any type of drill or power tool to operate the hand wind.

4.5 Electrical installation

4.5.1 General notes



- Make sure the leads/cables leading to the motor can handle the maximum motor current.
- An emergency stop is recommended to reduce the chance of a crushing hazard.
- Never work on the actuator or the wiring with the power switched on!

4.5.2 Fuse

Protect the actuator and the wiring by using a slow blow fuse between the actuator and the power source. The size of the fuse depends on the current draw of the actuator and local installation regulations and have to be determined on a case-to-case basis.

4.5.3 Power lead cross sections

To avoid malfunction due to voltage drop the cross section of the leads between the actuator power leads and the power source must be of sufficient size. The sufficient size is determined by calculations based on the supply voltage, current draw, length of the cables, ambient temperature and local regulations. The below tables show our minimum recommendations for a selection of different lead lengths. However, it is always the responsibility of the installer to make sure the installation is carried out in accordance with the local regulations.

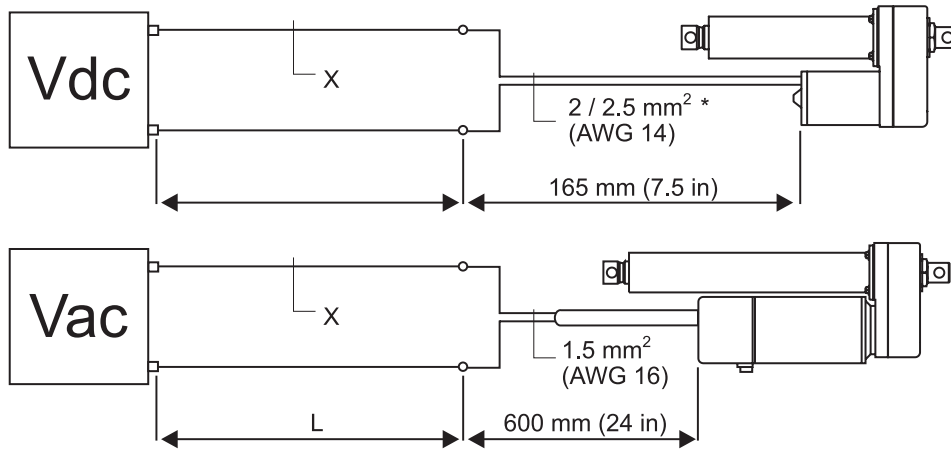

* Units with flying leads / units with cable and potentiometer option

Recommended Power Lead Cross Sections *			
Supply voltage	Length of leads (L) [m (ft)]	Max. current [A]	Min. recommended cross section (X) [mm ² (AWG)]
12 Vdc	0 - 3 (0 - 10)	0 - 15	1.5 (16)
		15 - 20	2.5 (14)
		20 - 28	4 (12)
		28 - 34	6 (10)
	3 - 6 (10 - 20)	0 - 15	2.5 (14)
		15 - 20	4 (12)
		20 - 34	6 (10)
	6 - 10 (20 - 33)	0 - 15	4 (12)
		15 - 20	6 (10)
20 - 34		10 (8)	
24 Vdc	0 - 10 (0 - 33)	0 - 10	1.5 (16)
		10 - 15	2.5 (14)
36, 48, 90 Vdc	0 - 10 (0 - 33)	0 - 15	1.5 (16)
115, 230, 400 Vac	0 - 20 (0 - 66)	0 - 6	1.5 (16)

* At an ambient temperature of 30 °C (86 °F) or less.

4.6.3 Installation of a dc input voltage actuator

Extend the actuator by connecting red to + Vdc and black (yellow)* leads to - Vdc in the cable. Change polarity to retract the actuator.

When reaching the mechanical end of stroke in any direction the built in slip clutch will engage and thus stop the extension tube movement in that direction. The clutch can also be engaged during mid stroke due to over load conditions, see section 4.4.5. Cut the electricity to the motor as quickly as possible when the clutch have been engaged irrespective of the reason.

Electrical Specifications		
Supply voltage	[Vdc]	see product label *
Supply voltage tolerance	[%]	± 10
Max. actuator current draw	[A]	see product label *

* if the unit has no product label, then see the engraved designation on the actuator housing and look the value up using the ordering code in section 6 and the technical specifications in section 5.

- F Fuse
- S1 Double pole double throw switch
- M Actuator motor

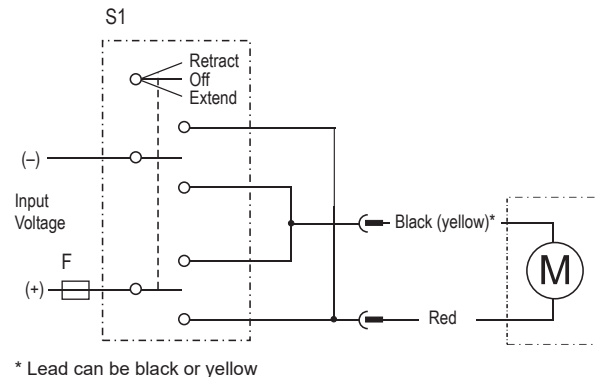

4.6.4 Installation of an one phase ac input voltage actuator

Leads can be either color or number marked. To be able to run the actuator, a capacitor must be connected between black (1) and red (2) leads. A 115 Vac actuator requires a 35 µF capacitor, while a 230 Vac actuator requires a 10 µF capacitor.

Connect black (1) lead to L1 and white (3) lead to N (neutral) to retract the actuator. Change L1 from lead black (1) to lead red (2) to extend the actuator.

The anti-coast brake must also be released during motion, which is done by connecting orange (4) lead to L1.

When reaching the mechanical end of stroke in any direction the built in slip clutch will engage and thus stop the extension tube movement in that direction. The clutch can also be engaged during mid stroke due to over load conditions, see section 4.4.5. Cut the electricity to the motor as quickly as possible when the clutch have been engaged irrespective of the reason.

Electrical Specifications		
Supply voltage	[Vac]	see product label *
Supply voltage tolerance	[%]	± 10
Max. actuator current draw	[A]	see product label *

* if the unit has no product label, then see the engraved designation on the actuator housing and look the value up using the ordering code in section 6 and the technical specifications in section 5.

- F Fuse
- S1 Double pole double throw switch
- M Actuator motor

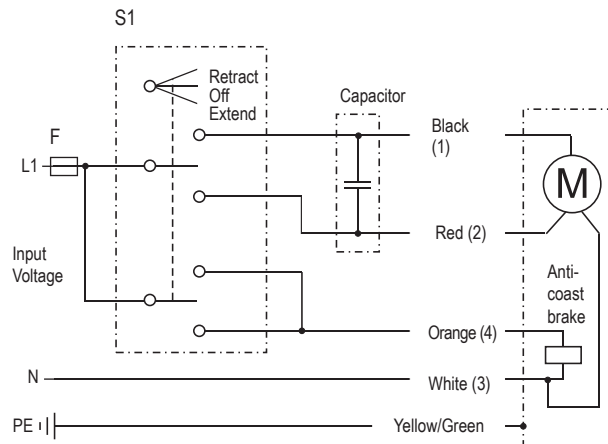

4.6.5 Installation of a three phase ac input voltage actuator

Leads can be either color or number marked. Connect white (1) lead to L1, red (2) lead to L2 and black (3) lead to L3 to extend the actuator. Change the places of white (2) lead and black (3) to retract the actuator. The anti-coast brake must also be released during motion, which is done by connecting orange (4) lead to neutral (N).

When reaching the mechanical end of stroke in any direction the built in clutch will engage and thus stop the extension tube movement in that direction. The clutch can also be engaged during mid stroke due to over load conditions, see section 4.4.5. Cut the electricity to the motor as quickly as possible when the clutch have been engaged irrespective of the reason.

Electrical Specifications		
Supply voltage	[Vac]	see product label *
Supply voltage tolerance	[%]	± 10
Max. actuator current draw	[A]	see product label *

* if the unit has no product label, then see the engraved designation on the actuator housing and look the value up using the ordering code in section 6 and the technical specifications in section 5.

- F Fuse
- K1 Relay / Contactor Extend
- K2 Relay / Contactor Retract
- M Actuator motor

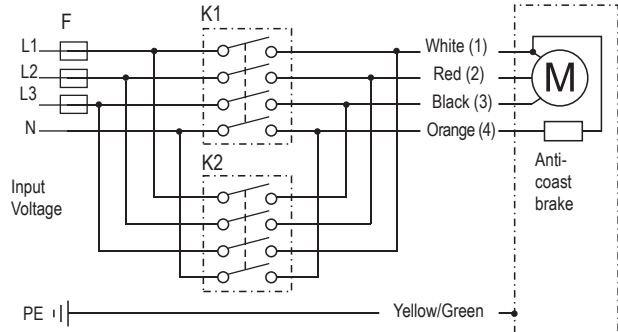

4.6.6 Installation of the feedback potentiometer (optional feature)

The potentiometer output has 0 ohm between grey and yellow leads when the actuator is fully extended.

Potentiometer Specifications		
Potentiometer max. input voltage	[Vdc]	32
Potentiometer max. power	[W]	2
Potentiometer linearity	[%]	± 0.25
Potentiometer output resolution	[ohm/mm]	
2 - 10 inch stroke		39
11 - 20 inch stroke		20
21 - 24 inch stroke		10
Potentiometer type		wirewound

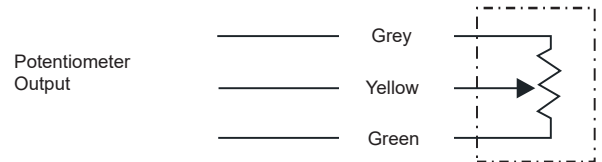

5. Technical specifications

5.1 General specifications

General Specifications	
Screw type	acme or ball
Nut type D(A)xxx-xxA (acme screw models) D(A)xxx-xxB (ball screw models)	self locking lead nut load lock ball nut
Manual override	no (optional)
Anti-rotation	no
Anti coast brake Dxx (dc voltage units) Axx (ac voltage units)	no yes
Static load holding brake D(A)xxx-xxA (acme screw) D(A)xxx-xxB (ball screw)	no (self locking) yes
Safety features	overload clutch (set to 1.2 - 1.5 × max. dynamic load) motor auto reset thermal switch

5.2 Weight for dc input voltage units

Weight													
Ordering stroke (S)	[in]	2	4	6	8	10	12	14	16	18	20	22	24
Weight, acme screw models	[kg]	4.4	4.6	4.8	5.0	5.1	5.3	5.5	5.6	5.8	5.9	6.1	6.2
	[lbf]	9.7	10.1	10.6	11.0	11.2	11.7	12.1	12.3	12.8	13.0	13.4	13.6
Weight, ball screw models	[kg]	5.0	5.2	5.4	5.6	5.8	6.0	6.1	6.2	6.4	6.5	6.7	6.9
	[lbf]	11.0	11.4	11.9	12.3	12.8	13.2	13.4	13.6	14.1	14.3	14.7	15.2
Add on weight for option potentiometer	[kg]	1.30											
	[lbf]	2.86											

5.3 Weight for ac input voltage units

Weight											
Ordering stroke (S)	[in]	6	8	10	12	14	16	18	20	22	24
Weight, acme screw models	[kg]	6.2	6.4	6.6	6.8	7.0	7.2	7.4	7.6	7.8	7.9
	[lbf]	13.6	14.1	14.5	15.0	15.4	15.8	16.3	16.7	17.1	17.4
Weight, ball screw models	[kg]	6.8	7.0	7.2	7.4	7.6	7.8	8.0	8.2	8.4	8.5
	[lbf]	15.0	15.4	15.8	16.3	16.7	17.1	17.6	18.0	18.5	18.8
Add on weight for option potentiometer	[kg]	1.3									
	[lbf]	2.86									

5.5 Technical data for dc input voltage units

Mechanical Specifications		
Max. static load @ fully retracted Dxx-xxA (acme screw models) Dxx-xxB (ball screw models)	[N (lbf)]	11350 (2500) 18000 (4000)
Max. dynamic load (Fx) Dxxx-05A5 Dxxx-10A5 Dxxx-20A5 Dxxx-05B5 Dxxx-10B5 Dxxx-20B5 Dxxx-21B5 Dxxx-2KB5	[N (lbf)]	1100 (250) 2250 (500) 2250 (500) 2250 (500) 4500 (1000) 4500 (1000) 6800 (1500) 9000 (2000)
Speed @ no load/max. load Dxxx-05A5 Dxxx-10A5 Dxxx-20A5 Dxxx-05B5 Dxxx-10B5 Dxxx-20B5 Dxxx-21B5 Dxxx-2KB5	[mm/s in/s]	54/32 (2.10/1.20) 30/18 (1.20/0.70) 15/12 (0.67/0.45) 61/37 (2.40/1.40) 30/19 (1.30/0.80) 15/12 0.60/0.45 15/11 (0.60/0.43) 15/9 (0.60/0.40)
Stroke (S) length Dxxx-xxx5-02 Dxxx-xxx5-04 Dxxx-xxx5-06 Dxxx-xxx5-08 Dxxx-xxx5-10 Dxxx-xxx5-12 Dxxx-xxx5-14 Dxxx-xxx5-16 Dxxx-xxx5-18 Dxxx-xxx5-20 Dxxx-xxx5-22 Dxxx-xxx5-24	[in]	2 4 6 8 10 12 14 16 18 20 22 24
Operating temperature limits	[°C (F)]	-25 – 65 (-15 – 150)
Full load duty cycle @ 25 °C (77 °F)	[%]	25
End play, maximum	[mm (in)]	1.0 (0.04)
Restraining torque	[Nm lbf-in]	11.3 (100)
Protection class - static Dxxx-xxx5-xxMxN Dxxx-xxx5-xxMxK		IP66 IP66 and IP69K

Electrical Specifications		
Input voltage D12 D24 D36 D48 D90	[Vdc]	12 24 36 48 90
Input voltage tolerance	[%]	± 10
Current draw @ no load/max. load D12x-05A5 D12x-10A5 D12x-20A5 D12x-05B5 D12x-10B5 D12x-20B5 D12x-21B5 D12x-2KB5 D24x-05A5 D24x-10A5 D24x-20A5 D24x-05B5 D24x-10B5 D24x-20B5 D24x-21B5 D24x-2KB5 D36x-05A5 D36x-10A5 D36x-20A5 D36x-05B5 D36x-10B5 D36x-20B5 D36x-21B5 D36x-2KB5 D48x-05A5 D48x-10A5 D48x-20A5 D48x-05B5 D48x-10B5 D48x-20B5 D48x-21B5 D48x-2KB5 D90x-05A5 D90x-10A5 D90x-20A5 D90x-05B5 D90x-10B5 D90x-20B5 D90x-21B5 D90x-2KB5	[A]	12.0/33.0 8.0/27.0 3.0/15.0 8.0/28.0 5.0/27.0 3.0/13.0 3.0/20.0 4.0/25.0 6.0/16.5 4.0/13.5 1.5/7.5 4.0/14.0 2.5/13.5 1.5/7.5 1.5/10.0 2.0/12.5 4.0/11.0 2.67/9.0 1.0/5.1 2.67/9.3 1.67/9.0 1.0/5.1 1.0/6.7 1.34/8.4 3.0/8.3 2.0/6.8 0.8/3.8 2.0/7.0 1.3/6.8 0.8/3.8 0.8/5.0 1.0/6.3 1.5/4.1 1.0/3.4 0.4/1.9 1.0/3.5 0.6/3.4 0.4/1.9 0.4/2.5 0.5/3.2
Flying leads length	[mm (in)]	165 (7.5)
Flying leads cross section	[mm ² (AWG)]	2 (14)
Cable length with option pot.	[mm (in)]	600 (24)
Cable leads cross section with option potentiometer motor leads potentiometer leads	[mm ² (AWG)]	2.5 (14) 1.5 (16)

5.6 Technical data for ac input voltage units

Mechanical Specifications		
Max. static load @ fully retracted Axx-xxA (acme screw models) Axx-xxB (ball screw models)	[N (lbf)]	11350 (2500) 18000 (4000)
Max. dynamic load (Fx) A12(22)C-05A5 A12(22)C-10A5 A42C-10A5 A12(22)C-20A5 A42C-20A5 A12(22)C-05B5 A42C-05B5 A12(22)C-10B5 A42C-10B5 A12(22)C-20B5 A42C-20B5 A12(22)C-21B5 A12(22)C-2KB5	[N (lbf)]	1100 (250) 2250 (500) 1100 (250) 2250 (500) 1100 (250) 2250 (500) 1100 (250) 4500 (1000) 2250 (500) 4500 (1000) 2250 (500) 6800 (1500) 9000 (2000)
Speed @ no load/max. load AxxC-05A5 AxxC-10A5 AxxC-20A5 AxxC-05B5 AxxC-10B5 AxxC-20B5 AxxC-21B5 AxxC-2KB5	[mm/s in/s]	54/32 (2.10/1.20) 30/18 (1.20/0.71) 15/12 (0.67/0.47) 61/37 (2.40/1.40) 30/18 (1.20/0.71) 15/12 (0.60/0.47) 15/11 (0.60/0.43) 15/9 (0.60/0.35)
Stroke (S) length Axxx-xxx5-06 Axxx-xxx5-08 Axxx-xxx5-10 Axxx-xxx5-12 Axxx-xxx5-14 Axxx-xxx5-16 Axxx-xxx5-18 Axxx-xxx5-20 Axxx-xxx5-22 Axxx-xxx5-24	[in]	6 8 10 12 14 16 18 20 22 24
Operating temperature limits	[°C (F)]	-25 – 65 (- 15 – 150)
Full load duty cycle @ 25 °C (77 °F)	[%]	25
End play, maximum	[mm (in)]	1.0 (0.04)
Restraining torque	[Nm lbf-in]	11.3 (100)
Protection class - static		IP45

Electrical Specifications		
Input voltage A12 A22 A42	[Vdc]	1 × 115 * 1 × 230 ** 3 × 400
Input voltage tolerance	[%]	± 10
Current draw @ no load/max. load A12C-05A5 A12C-10A5 A12C-20A5 A12C-05B5 A12C-10B5 A12C-20B5 A12C-21B5 A12C-2KB5 A22C-05A5 A22C-10A5 A22C-20A5 A22C-05B5 A22C-10B5 A22C-20B5 A22C-21B5 A22C-2KB5 A42C-10A5 A42C-20A5 A42C-05B5 A42C-10B5 A42C-20B5	[A]	1.2/2.8 1.2/2.8 0.8/2.2 1.0/2.8 1.0/2.8 1.0/2.4 0.8/2.8 0.8/3.7 0.6/1.4 0.6/1.4 0.4/1.4 0.5/1.3 0.5/1.3 0.5/1.4 0.4/1.6 0.4/1.8 0.35/0.7 0.30/0.7 0.45/0.7 0.45/0.7 0.45/0.7
Motor cable length	[mm (in)]	600 (24)
Motor cable leads cross section [mm ² (AWG)]		1.5 (16)
Potentiometer cable length	[mm (in)]	500 (20)
Pot. cable leads cross section [mm ² (AWG)]		1.5 (16)

* 35 µF (p/n 9200-448-002) capacitor required to run the actuator

** 10 µF (p/n 9200-448-003) capacitor required to run the actuator

6. Ordering keys

6.1 Ordering key for dc voltage models

Ordering Key									
Position	1	2	3	4	5	6	7	8	9
Example	D12C	05A5-	02	M0	N	N	-D	E	E

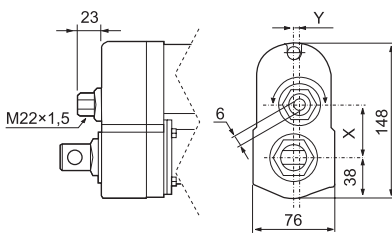
<p>1. Model, input voltage and CE compliance D12C = Electrak GX, 12 Vdc, CE compliant D24C = Electrak GX, 24 Vdc, CE compliant D36C = Electrak GX, 36 Vdc, CE compliant D48C = Electrak GX, 48 Vdc, CE compliant D12N = Electrak GX, 12 Vdc, not CE compliant D24N = Electrak GX, 24 Vdc, not CE compliant D36N = Electrak GX, 36 Vdc, not CE compliant D48N = Electrak GX, 48 Vdc, not CE compliant D90N = Electrak GX, 90 Vdc, not CE compliant</p> <p>2. Dynamic load capacity, screw type and maximum speed 05A5 - = 1100 N, acme, 54 mm/s 10A5 - = 2250 N, acme, 30 mm/s 20A5 - = 2250 N, acme, 15 mm/s 05B5 - = 2250 N, ball, 61 mm/s 10B5 - = 4500 N, ball, 30 mm/s 20B5 - = 4500 N, ball, 15 mm/s 21B5 - = 6800 N, ball, 15 mm/s 2KB5 - = 9000 N, ball, 9 mm/s</p> <p>3. Ordering stroke length 02 = 2 inch (50.8 mm) 04 = 4 inch (101.6 mm) 06 = 6 inch (152.4 mm) 08 = 8 inch (203.2 mm) 10 = 10 inch (254.0 mm) 12 = 12 inch (304.8 mm) 14 = 14 inch (355.6 mm) 16 = 16 inch (406.4 mm) 18 = 18 inch (457.2 mm) 20 = 20 inch (508.0 mm) 22 = 22 inch (558.8 mm) 24 = 24 inch (609.6 mm)</p> <p>4. Rear adapter hole orientation M0 = adapter at 0° (standard) M3 = adapter at 90° ⁽³⁾</p>	<p>5. Ingress protection rating N = IP66 K = IP66 and IP69K</p> <p>6. Options N = no option P = potentiometer feedback H = manual override</p> <p>Dimensions for manual override option</p>  <table border="1" style="margin-top: 10px;"> <thead> <tr> <th>Model</th> <th>X</th> <th>Y</th> </tr> </thead> <tbody> <tr> <td>DxxxO5A(B)5-</td> <td>49.6</td> <td>0.0</td> </tr> <tr> <td>Dxxx10A(B)5-</td> <td>43.3</td> <td>5.2</td> </tr> <tr> <td>Dxxx20(21, 2K)A(B)5-</td> <td>38.9</td> <td>0.0</td> </tr> </tbody> </table> <p>7. Connector option -A = AMP terminal 42098-2, house 180908-5 -B = Packard Electric 56 Series -D = no connector (flying leads)</p> <p>8. Front adapter option E = cross hole for 0.5 inch pin F = forked cross hole for 0.5 inch pin G = 1/2-20 UNF 2B female thread K = cross hole for 10 mm pin M = cross hole for 12 mm pin N = forked cross hole for 12 mm pin P = M12 female thread</p> <p>9. Rear adapter option E = cross hole for 0.5 inch pin K = cross hole for 10 mm pin M = cross hole for 12 mm pin</p> <p>(1) 21B5 not possible with strokes above 20 inch (2) 2KB5 not possible for strokes above 12 inch (3) Not possible with option manual override</p>	Model	X	Y	DxxxO5A(B)5-	49.6	0.0	Dxxx10A(B)5-	43.3	5.2	Dxxx20(21, 2K)A(B)5-	38.9	0.0
Model	X	Y											
DxxxO5A(B)5-	49.6	0.0											
Dxxx10A(B)5-	43.3	5.2											
Dxxx20(21, 2K)A(B)5-	38.9	0.0											

M0 - M3

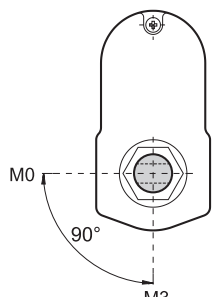

6.2 Ordering key for ac voltage models

Ordering Key								
Position	1	2	3	4	5	6	7	8
Example	A12C05A5-	06	M0	B	N	-D	E	E

1. Model, input voltage, dynamic load capacity, screw type, maximum speed

A12C05A5- = Electrak GX, 1 × 115 Vac, 1100 N, acme, 54 mm/s
 A12C10A5- = Electrak GX, 1 × 115 Vac, 2250 N, acme, 30 mm/s
 A12C20A5- = Electrak GX, 1 × 115 Vac, 2250 N, acme, 15 mm/s
 A12C05B5- = Electrak GX, 1 × 115 Vac, 2250 N, ball, 61 mm/s
 A12C10B5- = Electrak GX, 1 × 115 Vac, 4500 N, ball, 30 mm/s
 A12C20B5- = Electrak GX, 1 × 115 Vac, 4500 N, ball, 15 mm/s
 A12C21B5- = Electrak GX, 1 × 115 Vac, 6800 N, ball, 15 mm/s
 A12C2KB5- = Electrak GX, 1 × 115 Vac, 9000 N, ball, 10 mm/s
 A22C05A5- = Electrak GX, 1 × 230 Vac, 1100 N, acme, 54 mm/s
 A22C10A5- = Electrak GX, 1 × 230 Vac, 2250 N, acme, 30 mm/s
 A22C20A5- = Electrak GX, 1 × 230 Vac, 2250 N, acme, 15 mm/s
 A22C05B5- = Electrak GX, 1 × 230 Vac, 2250 N, ball, 61 mm/s
 A22C10B5- = Electrak GX, 1 × 230 Vac, 4500 N, ball, 30 mm/s
 A22C20B5- = Electrak GX, 1 × 230 Vac, 4500 N, ball, 15 mm/s
 A22C21B5- = Electrak GX, 1 × 230 Vac, 6800 N, ball, 15 mm/s
 A22C2KB5- = Electrak GX, 1 × 230 Vac, 9000 N, ball, 10 mm/s
 A42C10A5- = Electrak GX, 3 × 400 Vac, 1100 N, acme, 30 mm/s
 A42C20A5- = Electrak GX, 3 × 400 Vac, 1100 N, acme, 15 mm/s
 A42C05B5- = Electrak GX, 3 × 400 Vac, 1100 N, ball, 61 mm/s
 A42C10B5- = Electrak GX, 3 × 400 Vac, 2250 N, ball, 30 mm/s
 A42C20B5- = Electrak GX, 3 × 400 Vac, 2250 N, ball, 15 mm/s

2. Ordering stroke length

06 = 6 inch (152.4 mm)
 08 = 8 inch (203.2 mm)
 10 = 10 inch (254.0 mm)
 12 = 12 inch (304.8 mm)
 14 = 14 inch (355.6 mm)
 16 = 16 inch (406.4 mm)
 18 = 18 inch (457.2 mm)
 20 = 20 inch (508.0 mm)
 22 = 22 inch (558.8 mm)
 24 = 24 inch (609.6 mm)

3. Rear adapter hole orientation

M0 = adapter at 0° (standard)
 M3 = adapter at 90° (3)

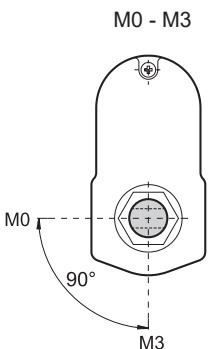

5. Ingress protection rating
 B = IP45

6. Options

N = no option
 P = potentiometer feedback
 H = manual override

Dimensions for manual override option

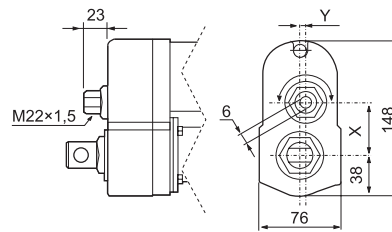

Model	X	Y
AxxxO5A(B)5-	49.6	0.0
Axxx10A(B)5-	43.3	5.2
Axxx20(21, 2K)A(B)5-	38.9	0.0

7. Connector option

-D = no connector (flying leads)

8. Front adapter option

E = cross hole for 0.5 inch pin
 F = forked cross hole for 0.5 inch pin
 G = 1/2-20 UNF 2B female thread
 K = cross hole for 10 mm pin
 M = cross hole for 12 mm pin
 N = forked cross hole for 12 mm pin
 P = M12 female thread

9. Rear adapter option

E = cross hole for 0.5 inch pin
 K = cross hole for 10 mm pin
 M = cross hole for 12 mm pin

(1) 21B5 not possible with strokes above 20 inch

(2) 2KB5 not possible for strokes above 12 inch

(3) Not possible with option manual override

Contact us or any of our 2000+ global distribution partners by scanning the code below
or visiting www.thomsonlinear.com/contact



RegalRexnord™

www.regalrexnord.com

www.thomsonlinear.com

Electrak_GX_Installation_Operation_MNEN-0011-02 | 20260121KB
Specifications are subject to change without notice. It is the responsibility of the product user to determine the suitability of this product for a specific application. All trademarks property of their respective owners. ©2026 Thomson Industries, Inc. | 2400 Curtiss Street, Downers Grove, IL 60515 USA

THOMSON®